

Mobile High Frequency Lifter

Mobile High Frequency Lifter

This product is a mobile version of our very popular High frequency lifter. Our most rapid lifter grips and lifts boxes and other packaged goods in no time. With a comfortable handle for one-hand use you can lift and move goods with very high frequency. Ideal for logistic centres and other operations where speed is essential.

The mobile version has an adjustable column and a parking which gives the unit a small foot print when not in use and is easy to move.

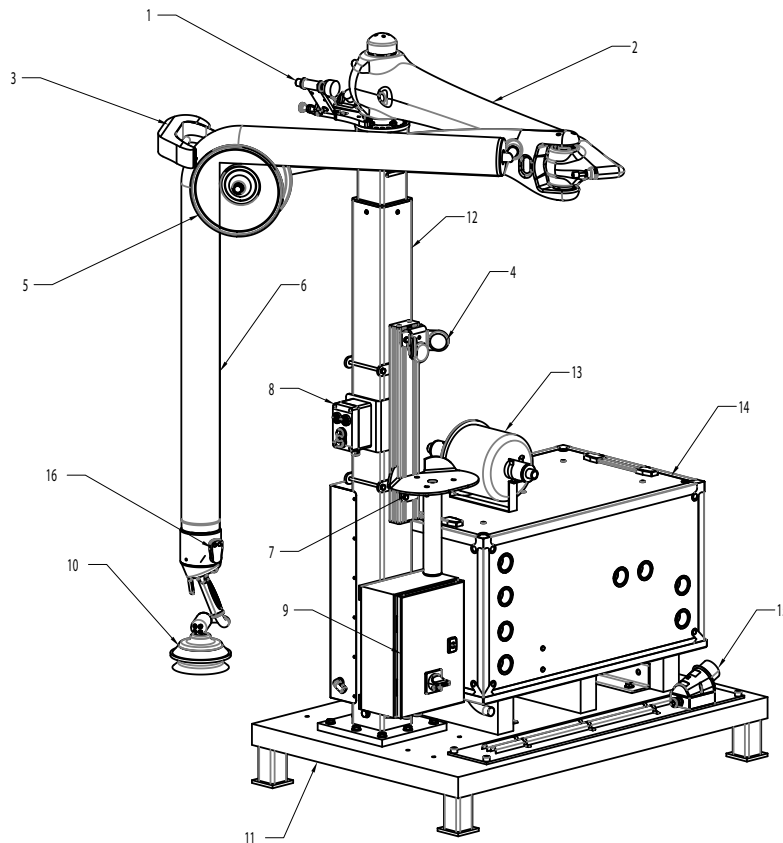

1	Travel limit	9	Mains cabinet and switch
2	Articulating jib crane	10	Lift unit
3	Collision shock absorber	11	Base plate
4	Magnet holder connector	12	Adjustable column
5	Support wheel	13	Vacuum filter
6	Lift tube	14	Pump unit
7	Parking	15	Power inlet
8	Control box	16	Remote for up&down of column



The Mobile High Frequency Lifter in use

Highlights

- Mobile Plug&Play solution
- Compact design
- Intuitive and easy to use
- Suitable for container unloading

TAWI

TAWI AB

Box 10205
434 23 Kungsbacka
Sweden

+46 300 185 00
la.info@piab.com
www.tawi.com

Mobile High Frequency Lifter

Technical specification

Product model	MHL40 / MHL50
Max load*	40kg / 50kg
Arm type	Carbon arm / Steel arm
Total weight	695kg
Sound level**	55dBA
Power	2,2kW / 2,6kW
Frequency	50Hz / 60Hz
Voltage (3-Phase N + PE)	200V / 220V / 230V / 265V / 400V / 460V
Lifting speed	0-1m/s
Colour	Black
Enviroment	Normal indoor industrial enviroment
Labeling	CE and UKCA***

* For air tight objects
** 1 meter from control handle
*** To be introduced 2023

Available suction feet MHL40

4000168	Suction foot. Dim 150x210mm
4000133	Baggage Foot 245x125 Grid Cpl
4000215	Single bellow cup. Dim Ø150mm

Available suction feet MHL50

4000168	Suction foot. Dim 150x210mm
4000139	Baggage Foot 290x150 With Grid Cpl

More TP suction feet can be used but these are the ones that fits the parking plate

If multiple tools are to be used, the lifter and each tool has to be equipped with a quick connection

4000220	Quick Disconnection Upper
4000224	Quick Disconnection Lower

Mobile High Frequency Lifter

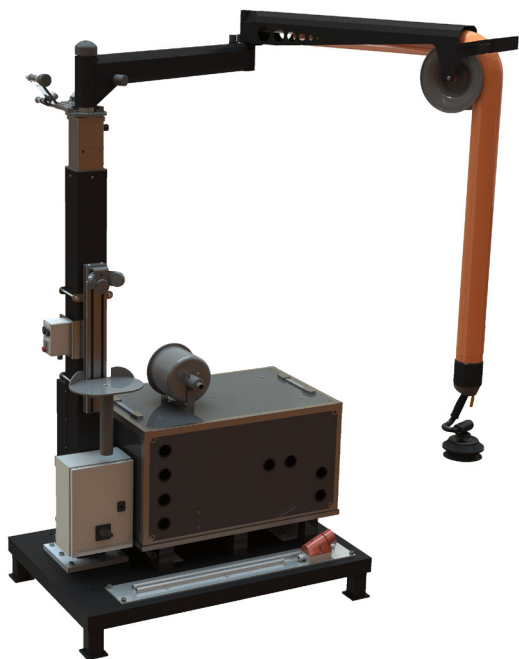

Available standard configurations

MHL40-S-H100-B150-0
MHL40-C-H100-B150-EU
MHL40-S-H100-B150-1
MHL40-C-H100-B150-1
MHL40-S-H100-B150-2
MHL40-C-H100-B150-2
MHL40-S-H100-Z-0
MHL40-C-H100-Z-0
MHL40-S-H100-Z-1
MHL40-C-H100-Z-1
MHL40-S-H100-Z-2
MHL40-C-H100-Z-2
MHL50-S-H120-Z-0
MHL50-C-H120-Z-0
MHL50-S-H120-Z-1
MHL50-C-H120-Z-1
MHL50-S-H120-Z-2
MHL50-C-H120-Z-2

Product configuration key

Max load	Arm material	Lifting unit	Suction foot	Power
MHL40=40kg	S=Steel	H100=TPH40	0=Bellow cup	0= 400-460V/50-60Hz
MHL50=50kg	C=Carbon	H120=TPH50	Z=Tool adapter	1=230-265V/50-60Hz
				2=200-220V/50-60Hz

Mobile High Frequency Lifter

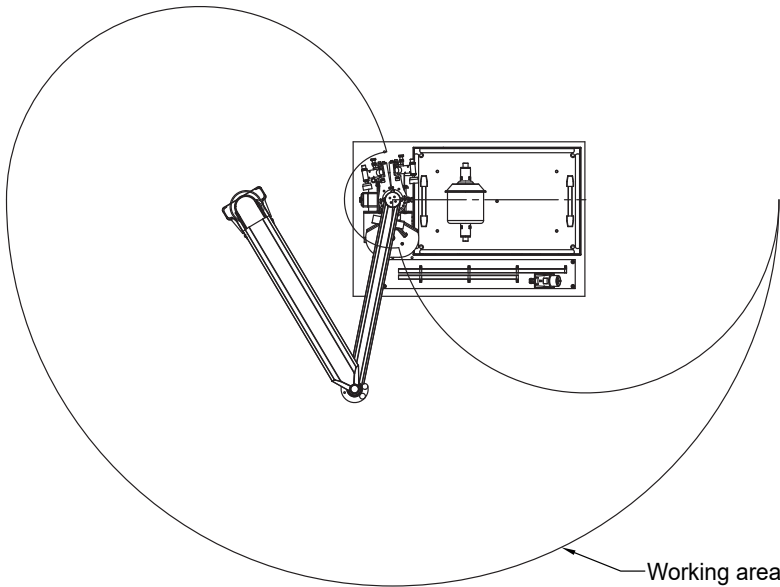
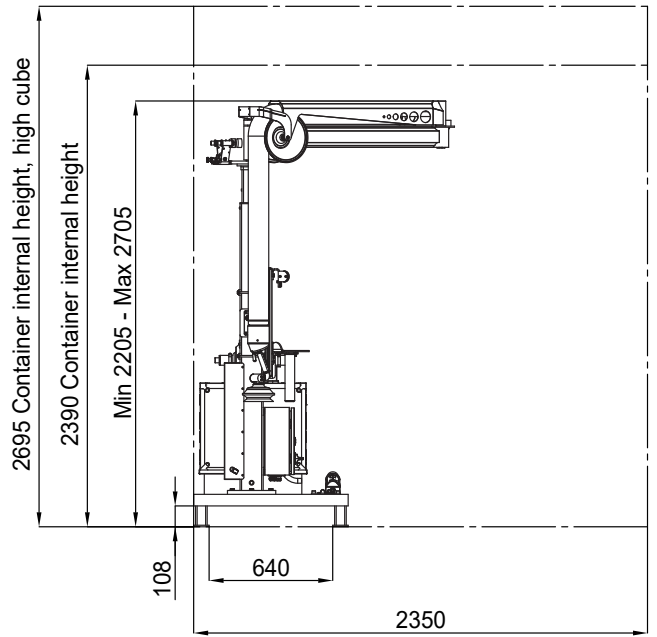
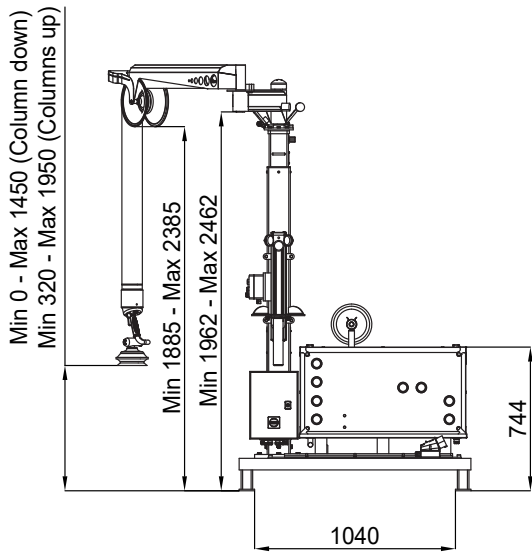

Mobile High Frequency Lifter

